

ELEVATIONS ONLY--  
NOZZLES & ACCESSORIES  
ROTATED INTO VIEW--  
FOR TRUE ORIENTATION  
SEE PLAN VIEW

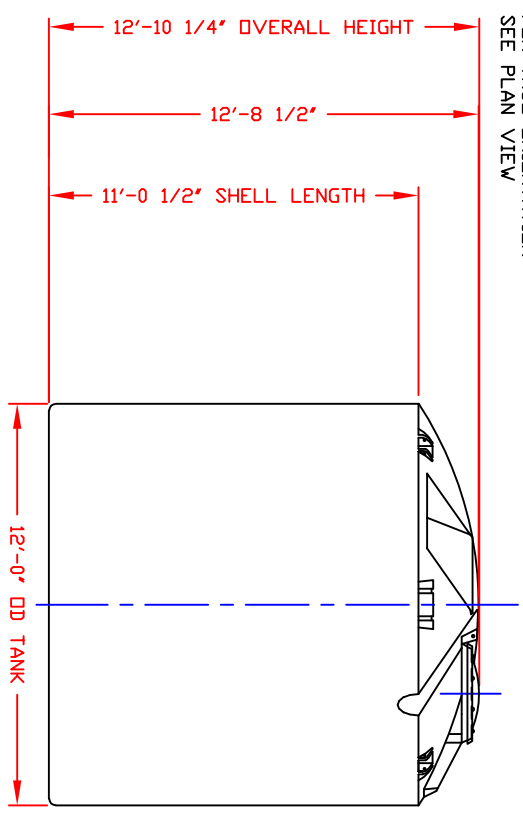

NOTE:  
MUST USE FLEXIBLE  
CONNECTIONS ALL  
LOWER SIDEWALL  
FITTINGS

- NOTES
1. THIS IS A COMPUTER GENERATED DWG. DO NOT REVISE BY HAND.
  2. DIMENSIONS WILL VARY ±3% DUE TO VARIATIONS IN MULTIPLE MOLDS & CONDITIONS PREVALENT DURING MANUFACTURE & USAGE.
  3. NO MOLDED IN GALLONAGE MARKERS THIS TANK.
  4. TANK DESIGNED FOR 1.9 SPG MAT'L @ 100°F/ATMDS PRESSURE

CALCULATED CAPACITIES/ VOLUME IN U.S. GALLONS		
DESIGN CAP	DOME VOL	TOTAL VOL
9140	640	9780

DWG TITLE: 9100 GALLON UPRIGHT TANK

SCALE: 1/4"=1'-0"

SERVICE:XXXXXXXX

DATE: 10/17/19

DR: B. HARPER

1.9 SpG/XLPE/NATURAL STOCK ND: 11009100410

Western Region  
1000 South Ave Street  
Carmel, IN 46032  
TEL: (317) 835-4400  
FAX: (317) 835-4405

POLYPROCESSING SOLUTIONS, SIMPLIFIED

1 OF 1 SHEET COMPUTER FILE VERT-09100