

NON-CONTROLLED COPY  
 INFORMATION SUBJECT TO CHANGE WITHOUT NOTICE  
 VERIFY REV LEVEL OF PAPER COPY WITH REV LEVEL ON PPC WEB SITE

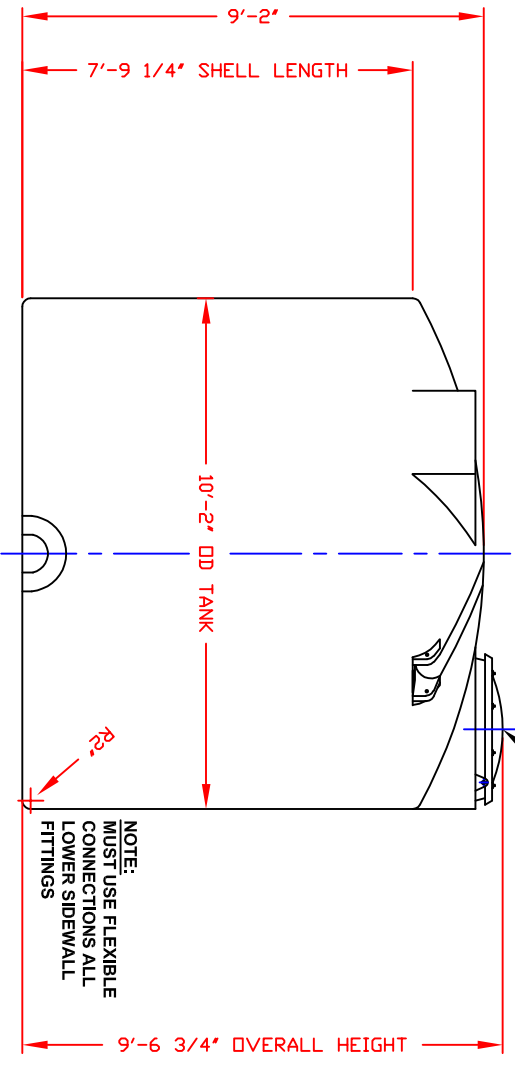
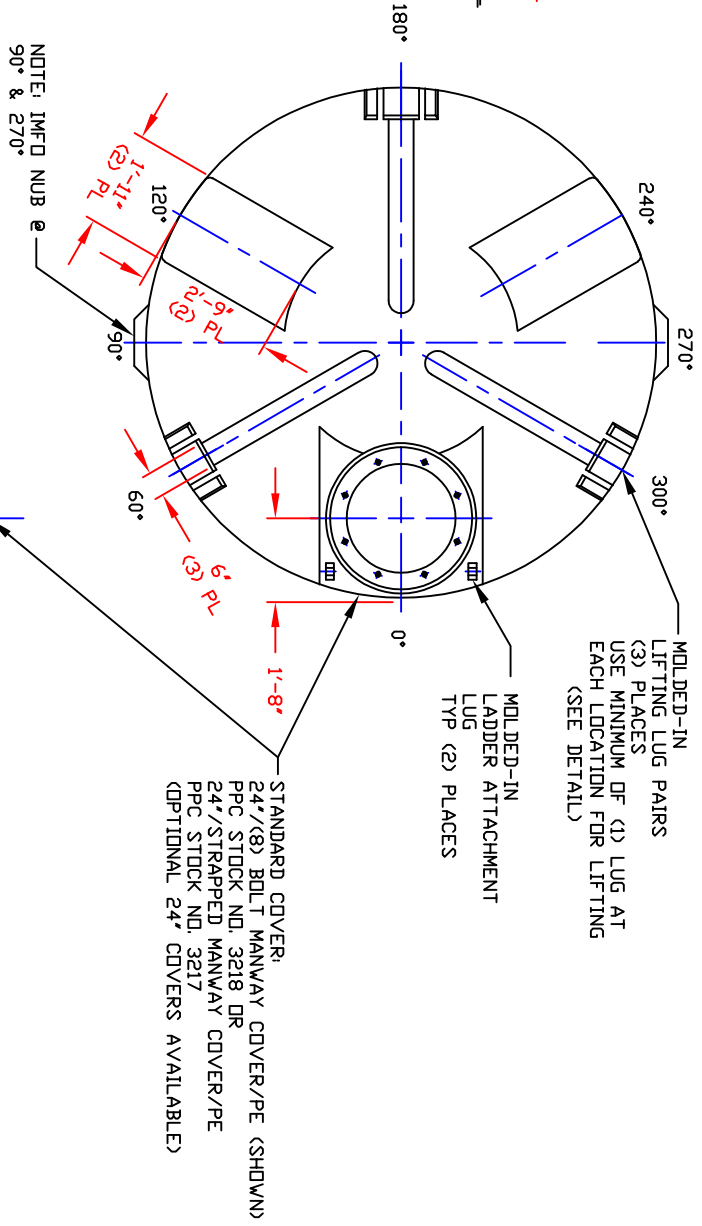
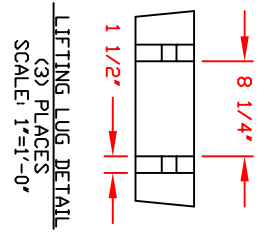

NOTE:  
 MUST USE FLEXIBLE CONNECTIONS ALL LOWER SIDEWALL FITTINGS

- NOTES**
1. THIS IS A COMPUTER GENERATED DWG. DO NOT REVISE BY HAND.
  2. DIMENSIONS WILL VARY ±3% DUE TO VARIATIONS IN MULTIPLE MOLDS & CONDITIONS PREVALENT DURING MANUFACTURE & USAGE.
  3. MOLDED IN GALLONAGE MARKERS @ 355" IN 200 GALLON INCREMENTS.

CALCULATED CAPACITIES/ VOL VOLUME IN U.S. GALLONS	
DESIGN CAP DOME VOL/TOTAL VOL	
4610	434
	5044

CONFIDENTIAL PROPERTY OF  
 POLY PROCESSING COMPANY  
 NOT FOR REPRINT OR USE  
 WITHOUT PERMISSION

DWG TITLE		4600 GALLON UPRIGHT TANK	
SCALE:	3/8"=1'-0"	 POLY PROCESSING SOLUTIONS, INC. Western Region 4600 South 4th Street Cedar Rapids, IA 52404 FAX: (319) 396-4800	DR: B. HARPER
DATE:	10/17/19		CK:
SHEET	1 OF 1	COMPUTER FILE	REV
			-