

NON-CONTROLLED COPY

INFORMATION SUBJECT TO CHANGE WITHOUT NOTICE
 VERIFY REV LEVEL OF PAPER COPY WITH REV LEVEL ON PPC WEB SITE

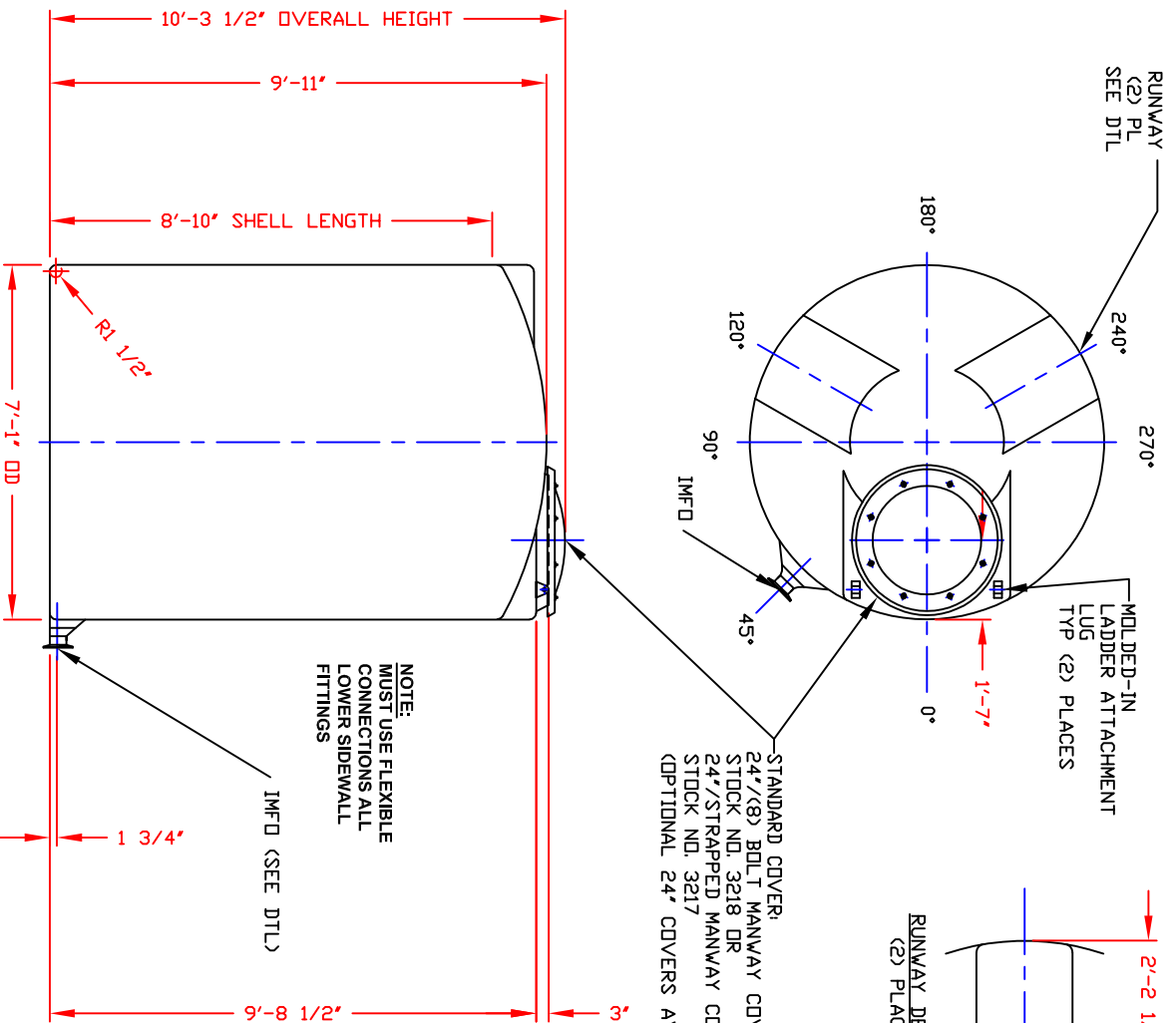

NOZZLE SCHEDULE & ACCESSORIES		DEG ELEV
SERVICE	MK STOCK NO/ SIZE	FITTING

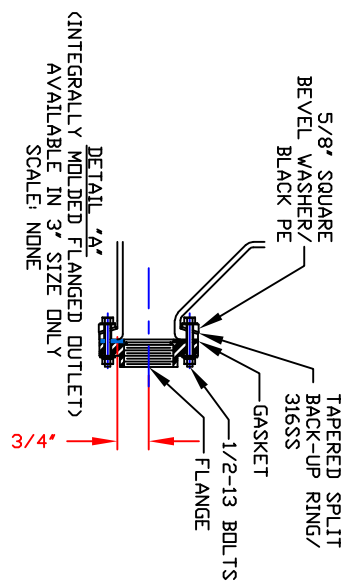

- NOTES**
- THIS IS A COMPUTER GENERATED DWG. DO NOT REVISE BY HAND.
 - DIMENSIONS WILL VARY ±3% DUE TO VARIATIONS IN MULTIPLE MOLDS & CONDITIONS PREVALENT DURING MANUFACTURE & USAGE.
 - MOLDED IN GALLONAGE MARKERS @ APPROX 60" IN 200 GAL INCREMENTS UP TO 2400 GAL.

CALCULATED CAPACITIES/ VOLUME IN U.S. GALLONS	
DESIGN CAP DOME VOLUME	2559
DESIGN CAP DOME VOLUME	142
TOTAL VOL	2701

CONFIDENTIAL PROPERTY OF POLY PROCESSING COMPANY NOT FOR REPRINT OR USE WITHOUT PERMISSION

DWG TITLE: 2560 GALLON IMF0 TANK

SCALE: 3/8"=1'-0"
 DATE: 09/19/19

 Central Region
 PAID FOR BY CUSTOMER
 MADE IN THE U.S.A.
 CONFIDENTIAL PROPERTY OF POLY PROCESSING COMPANY NOT FOR REPRINT OR USE WITHOUT PERMISSION
 DR: B. HARPER
 CK:
 SHEET 1 OF 1
 COMPUTER FILE: IMF0-F-02560
 REV A