

NON-CONTROLLED COPY  
 INFORMATION SUBJECT TO CHANGE WITHOUT NOTICE  
 VERIFY REV LEVEL OF PAPER COPY WITH REV LEVEL ON PPC WEB SITE

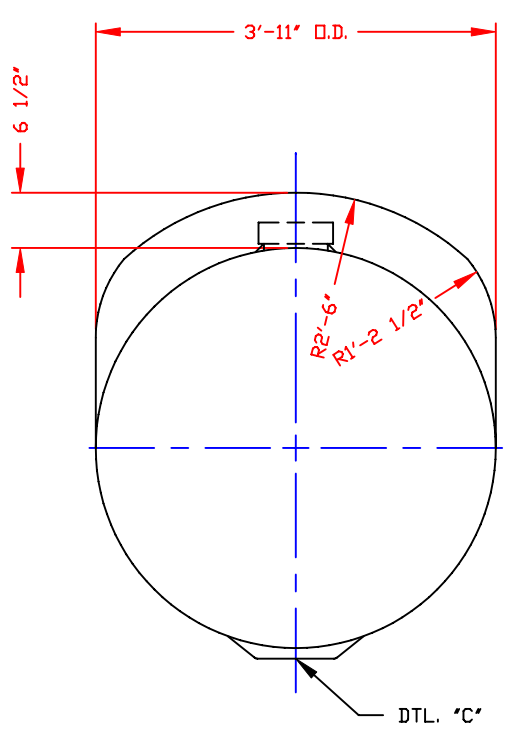

LEFT END

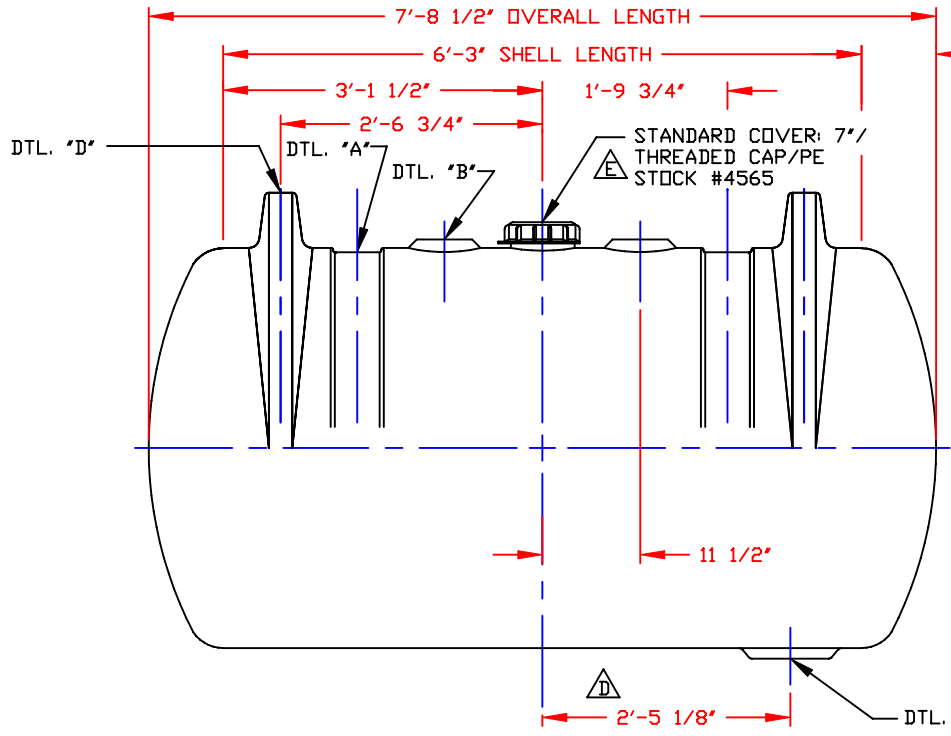

ELEVATION

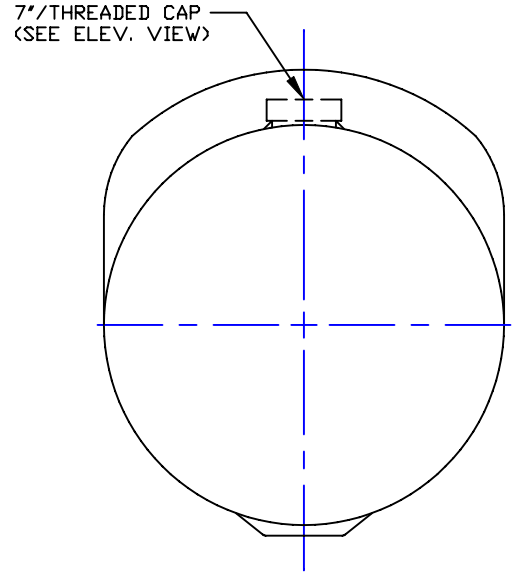

RIGHT END

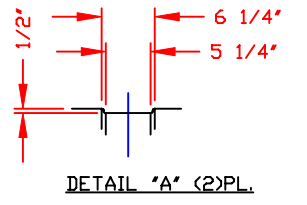

DETAIL 'A' (2) PL.

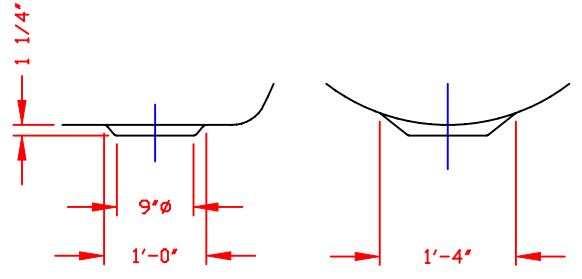

DETAIL 'C'

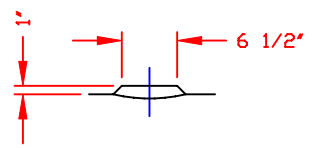

DETAIL 'B' (2) PL.

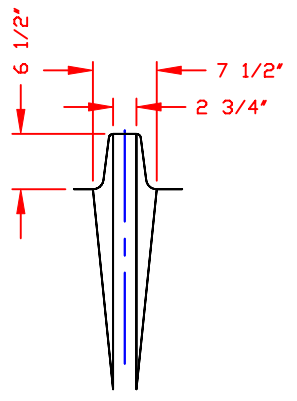

DETAIL 'D'

**NOTES**

1. THIS IS A COMPUTER GENERATED DWG. DO NOT REVISE BY HAND.
2. COMPUTER DWG. NAME "610HT2."
3. NO MOLDED IN GALLONAGE MARKERS THIS TANK.
4. DIMENSIONS MAY VARY SLIGHTLY DUE TO VARIATIONS IN MULTIPLE MOLDS.
5. PPC STOCK #TP017.

REV. 'F'	CALCULATED CAPACITY DELETED/CAPACITY BY WEIGHT ADDED BY:D.R. 7-8-97 CK:K.H.
REV. 'E'	ADDED CALCULATED CAPACITIES/CAP/STOCK NUMBERS BY:JLB 2/24/97 CK:DR
REV. 'D'	DIM. CORRECTED WAS 2'-4 1/2" BY:D.R. 3-28-96 CK:K.H.
REV. 'C'	REVISED & REDRAWN BY:D.R. 1-23-96 CK:K.H.
REV. 'B'	REVISED AND REDRAWN TO REFLECT MOLDED TANK. BY:D.R. 1-17-96 CK:K.H.
REV. 'A'	REVISED AND REDRAWN BY:D.R. 11-7-95 CK:W.T.

DWG. TITLE			
610 GALLON HORIZONTAL PORTABLE TANK			
SCALE:	3/4"=1'-0"	DR:	D. RECTOR
DATE:	10-23-95	CK:	W. THURMON
SHEET:		DWG. NO.	REV.
1 OF 1		PPC102395-5	F

TANK CAPACITY BASED ON WEIGHTS EMPTY & FULL OF TESTED TANK = 623 GAL.