

NON-CONTROLLED COPY
 INFORMATION SUBJECT TO CHANGE WITHOUT NOTICE
 VERIFY REV LEVEL OF PAPER COPY WITH REV LEVEL ON PPC WEB SITE

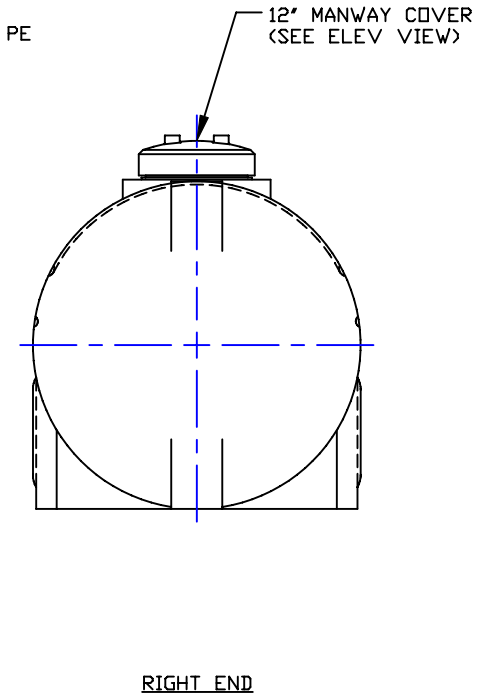

NOTES

1. THIS IS A COMPUTER GENERATED DWG. DO NOT REVISE BY HAND.
2. DIMENSIONS WILL VARY ±3% DUE TO VARIATIONS IN MULTIPLE MOLDS & CONDITIONS PREVALENT DURING MANUFACTURE & USAGE.
3. MOLDED IN GALLONAGE MARKER IN ONE END STARTING @ 30 GAL UP TO 200 GALLONS. AVOID WHEN PLACING FITTINGS.

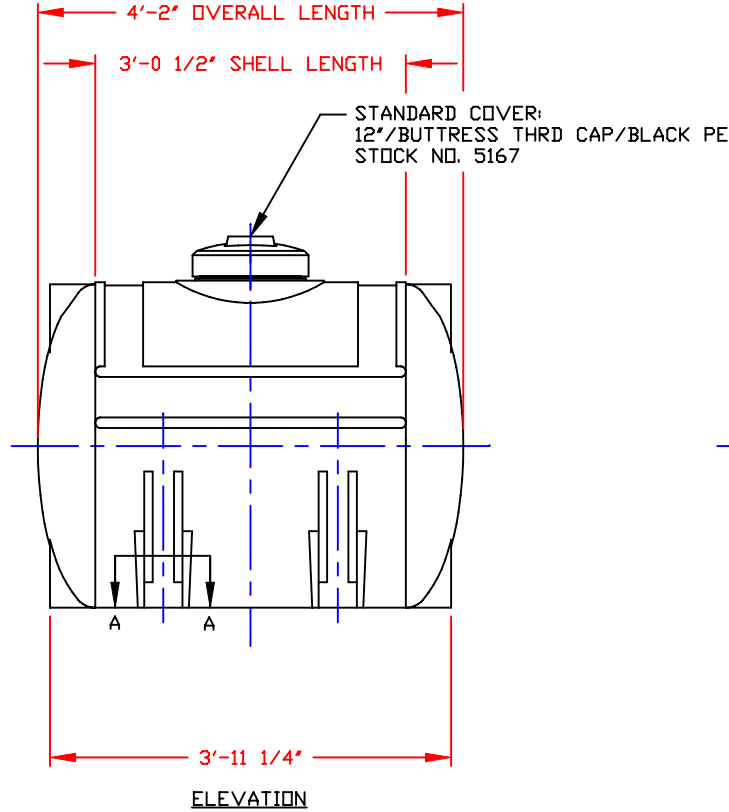
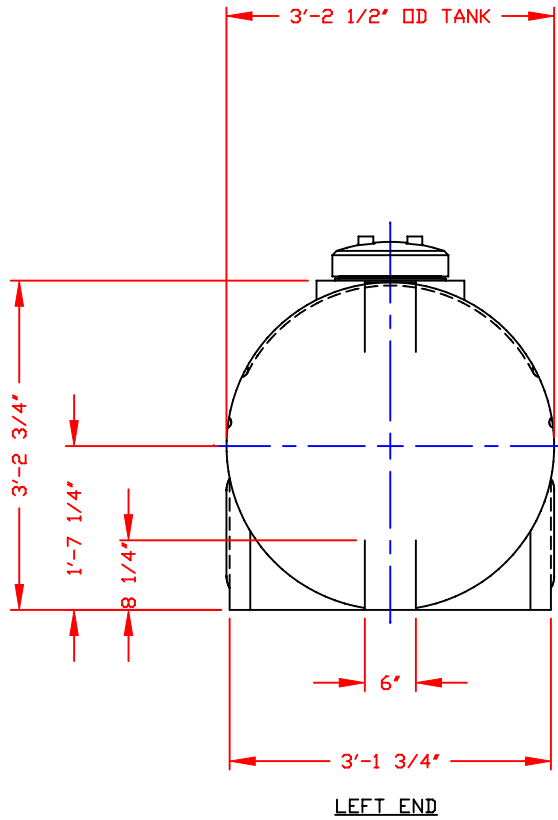
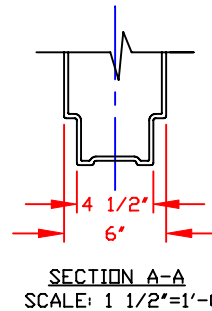

CALCULATED CAPACITIES/ VOLUME IN U.S. GALLONS
DESIGN CAPACITY
220

CONFIDENTIAL PROPERTY OF
 POLY PROCESSING COMPANY
 NOT FOR REPRINT OR USE
 WITHOUT PERMISSION

DWG TITLE			
220 GALLON HORIZONTAL LEG TANK			
SCALE:	3/4"=1'-0"	 POLYPROCESSING COMPANY	DR:
DATE:	8/8/00		CK:
		Central Region <small>P.O. Box 4150 71210 2201 Old Sterlington Rd. Monroe, LA 71203 (504) 345-7565 FAX (504) 345-8795</small>	MB WILKERSON
		J. BRANTLEY	
		SHEET	COMPUTER FILE
		1 OF 1	3400220 A

REVISION "A" REVISED TOP SUMP BOTH ENDS BY:BD 12/7/2007 CK:JB