

NON-CONTROLLED COPY INFORMATION SUBJECT TO CHANGE WITHOUT NOTICE COPY WILL <u>NOT</u> BE UPDATED	COPY ISSUED BY..... COPY ISSUED ON.....
--	--

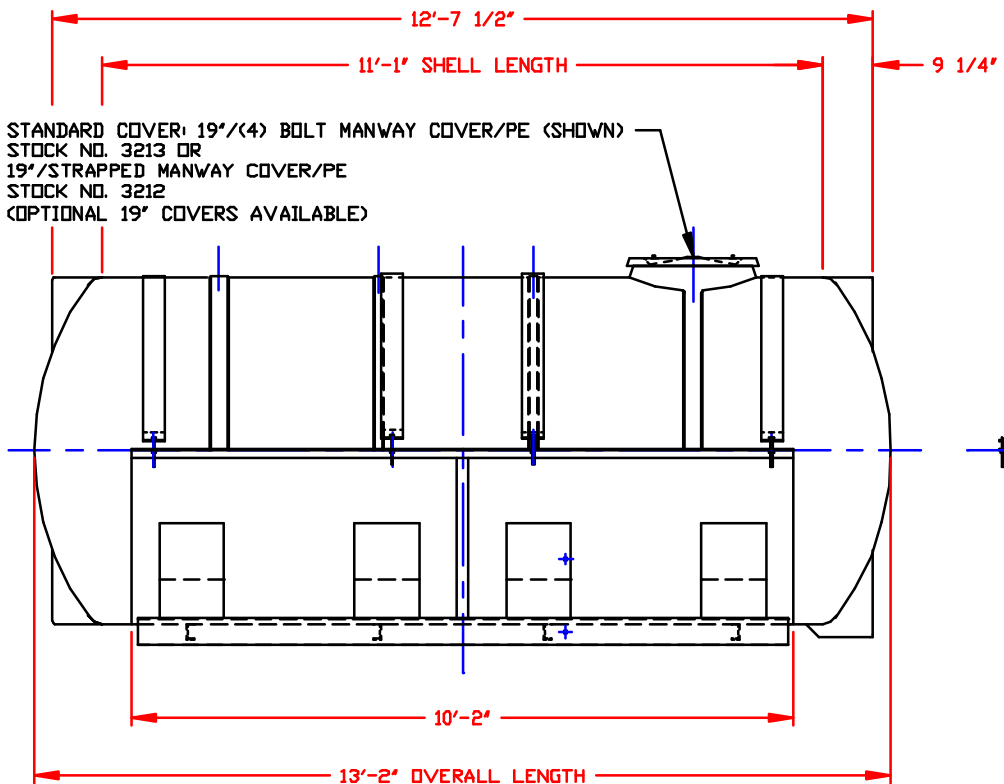

STANDARD COVER: 19"/(4) BOLT MANWAY COVER/PE (SHOWN)
STOCK NO. 3213 OR
19"/STRAPPED MANWAY COVER/PE
STOCK NO. 3212
(OPTIONAL 19" COVERS AVAILABLE)

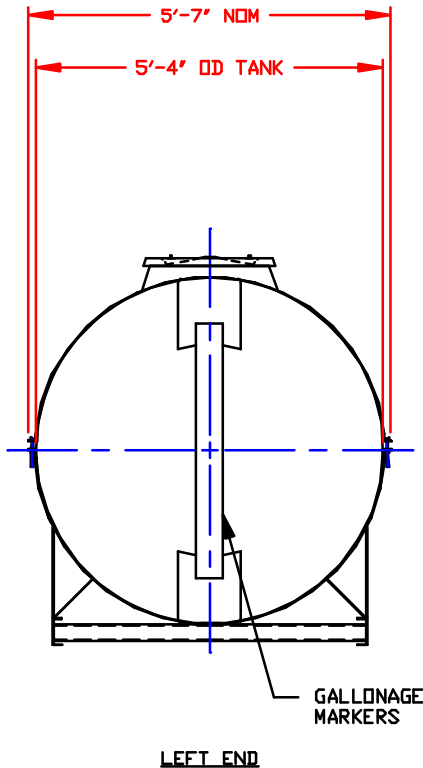
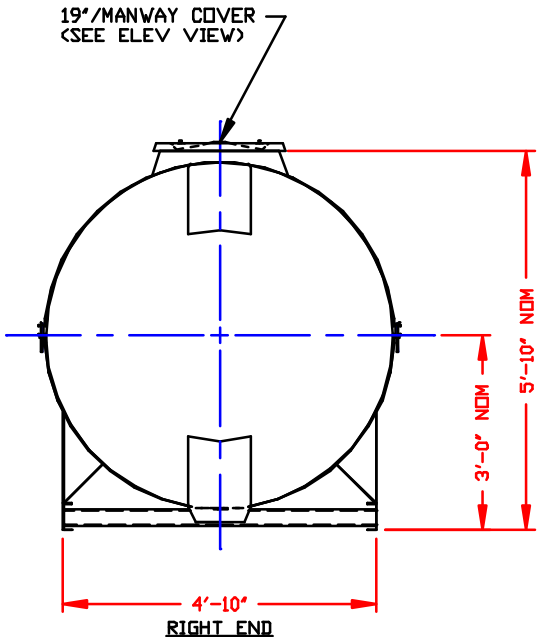

- NOTES**
1. THIS IS A COMPUTER GENERATED DWG. DO NOT REVISE BY HAND.
 2. DIMENSIONS WILL VARY ±3% DUE TO VARIATIONS IN MULTIPLE MOLDS & CONDITIONS PREVALENT DURING MANUFACTURE & USAGE.
 3. 5" WIDE MOLDED IN GALLONAGE MARKERS UP TO 1800 GAL LEFT END ONLY. AVOID WHEN PLACING FTGS.
 4. FOR TANK DTLS SEE COMPUTER FILE NO. 3001950
FOR SKID DTLS SEE COMPUTER FILE NO. M3464.

CALCULATED CAPACITY VOLUME IN U.S. GALLONS
DESIGN CAPACITY
1965

CONFIDENTIAL PROPERTY OF
POLY PROCESSING COMPANY
NOT FOR REPRINT OR USE
WITHOUT PERMISSION

DWG TITLE		1950 GALLON HORIZONTAL TANK & SKID	
SCALE: 1/2"=1'-0"		DR: MB WILKERSON	REV
DATE: 1/20/00		CK: J. BRANTLEY	-
SHEET		COMPUTER FILE	REV
1 OF 1		3001950S	-