

NON-CONTROLLED COPY

INFORMATION SUBJECT TO CHANGE WITHOUT NOTICE

COPY WILL NOT BE UPDATED

COPY ISSUED BY.....

COPY ISSUED ON.....

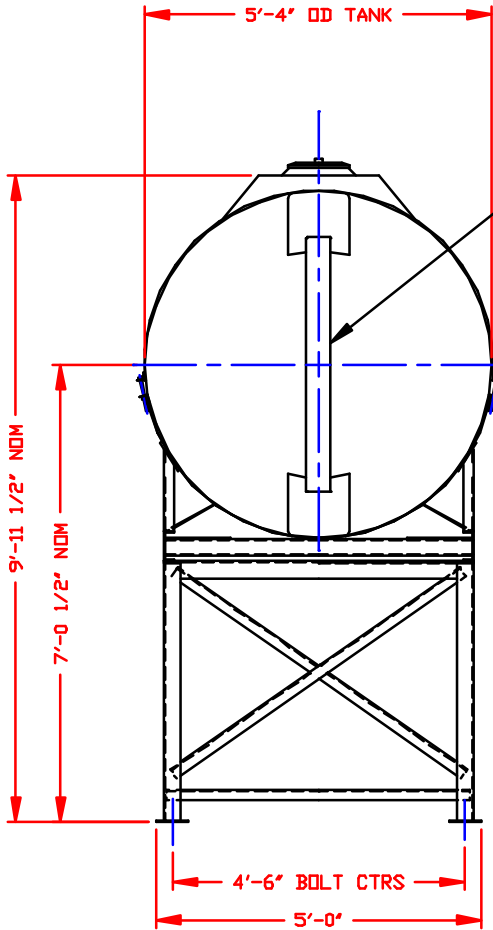

LEFT END

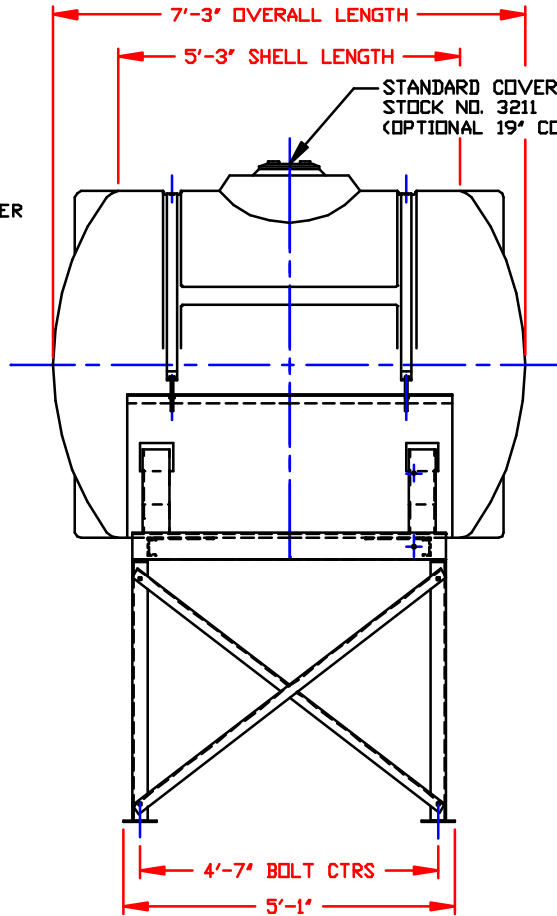

ELEVATION

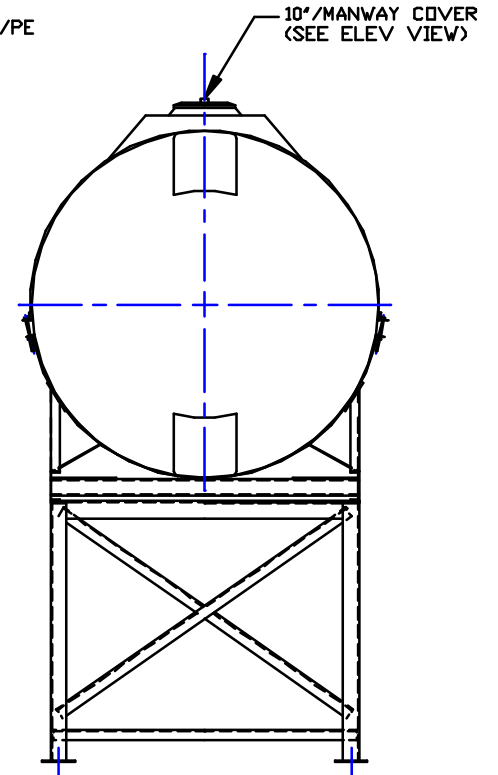

RIGHT END

NOTES:

1. THIS IS A COMPUTER GENERATED DWG. DO NOT REVISE BY HAND.
2. DIMENSIONS WILL VARY ±3% DUE TO VARIATIONS IN MULTIPLE MOLDS & CONDITIONS PREVALENT DURING MANUFACTURE & USAGE.
3. 4 1/2" MOLDED IN GAL MARKERS UP TO 900 GAL LEFT IN ONLY. AVOID WHEN PLACING FTGS.
4. FOR TANK DTLS SEE COMPUTER FILE NO. 3001000.

CALCULATED CAPACITY
VOLUME IN U.S. GALLONS
DESIGN CAPACITY
1022

CONFIDENTIAL PROPERTY OF
POLY PROCESSING COMPANY
NOT FOR REPRINT OR USE
WITHOUT PERMISSION

DWG TITLE			
1000 GALLON HORIZONTAL TANK W/SKID W/4 FT STAND			
SCALE:	1/2"=1'-0"		DR: MB WILKERSON
DATE:	2/8/00		CK: D. RECTOR
SHEET		COMPUTER FILE	REV
1 OF 1		3001000S4	-