

NON-CONTROLLED COPY

INFORMATION SUBJECT TO CHANGE WITHOUT NOTICE

COPY WILL NOT BE UPDATED

COPY ISSUED BY.....

COPY ISSUED ON.....

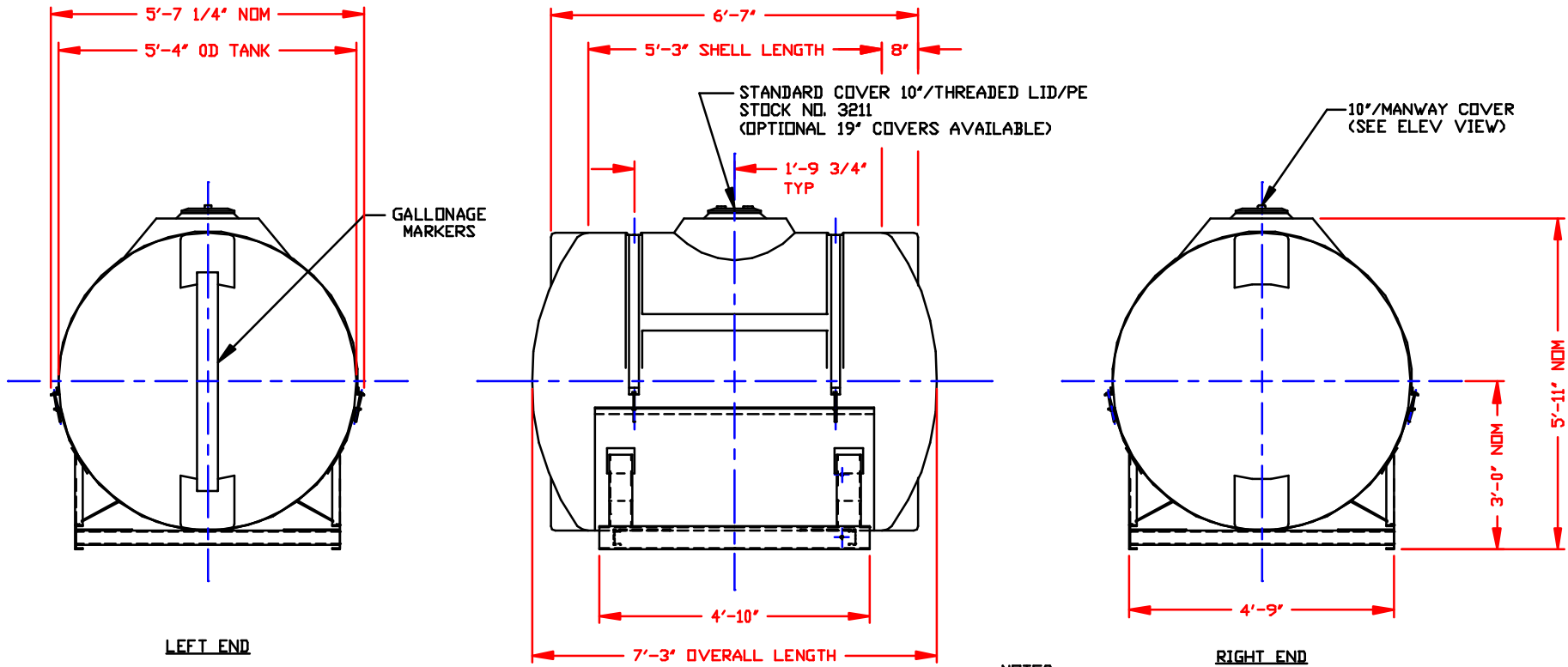

ELEVATION

RIGHT END

NOTES

1. THIS IS A COMPUTER GENERATED DWG. DO NOT REVISE BY HAND.
2. DIMENSIONS WILL VARY ±3% DUE TO VARIATIONS IN MULTIPLE MOLDS & CONDITIONS PREVALENT DURING MANUFACTURE & USAGE.
3. 4 1/2" MOLDED IN GAL MARKERS UP TO 900 GAL IN LEFT END ONLY. AVOID WHEN PLACING FITTINGS.
4. FOR TANK DTLS SEE COMPUTER FILE NO. 3001000S FOR SKID DTLS SEE COMPUTER FILE NO. M3459.

CALCULATED CAPACITY
VOLUME IN U.S. GALLONS
DESIGN CAPACITY
1022

CONFIDENTIAL PROPERTY OF
POLY PROCESSING COMPANY
NOT FOR REPRINT OR USE
WITHOUT PERMISSION

DWG TITLE			
1000 GALLON HORIZONTAL TANK & SKID			
SCALE: 1/2"=1'-0"		<small>Control Number</small> <small>PLS. SEE 3001000S</small> <small>ISSUE NO. 1</small> <small>ISSUE DATE 1/20/00</small> <small>ISSUE BY J.B.</small> <small>DATE 1/20/00</small> <small>FILE NO. 3001000S</small>	DR: MB WILKERSON
DATE: 1/20/00		CK: J. BRANTLEY	
SHEET		COMPUTER FILE	REV
1 OF 1		3001000S	-