

NON-CONTROLLED COPY
 INFORMATION SUBJECT TO CHANGE WITHOUT NOTICE
 COPY WILL NOT BE UPDATED

COPY ISSUED BY.....
 COPY ISSUED ON.....

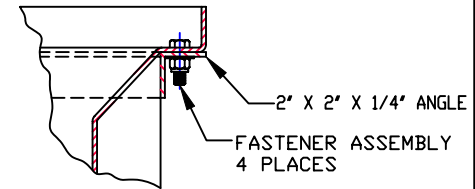

DETAIL "A"
 ANGLE ASSEMBLY STANDARD
 W/1.65 & 1.90 SpG TANKS.
 OPTIONAL W/1.35 SpG TANKS

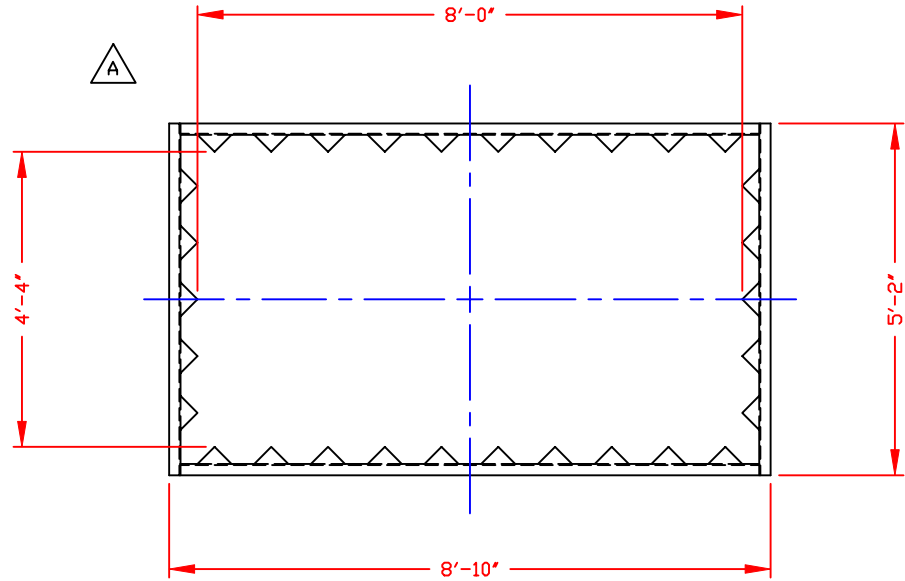
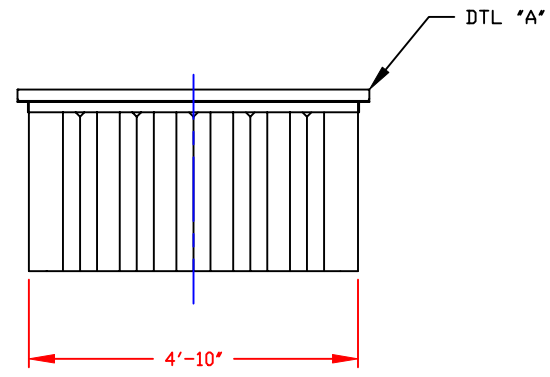
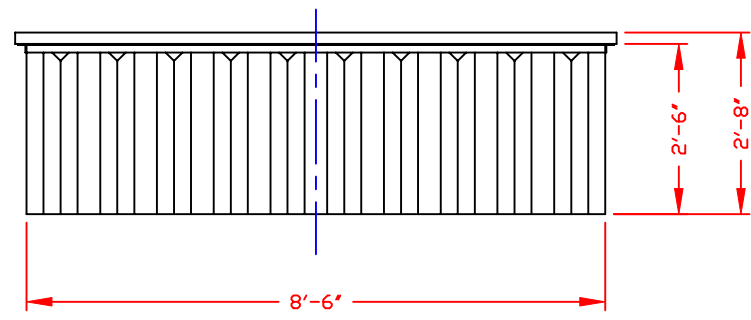

NOTE: CAPACITIES OF RECTANGULAR SECONDARY CONTAINMENT BASINS MAY BE SIGNIFICANTLY LESS THAN NOMINAL VOLUME WITHOUT ADEQUATE EXTERNAL SUPPORT.

- NOTES**
1. THIS IS A COMPUTER GENERATED DWG. DO NOT REVISE BY HAND.
 2. DIMENSIONS WILL VARY ±3% DUE TO VARIATIONS IN MULTIPLE MOLDS & CONDITIONS PREVALENT DURING MANUFACTURE & USAGE.
 3. NO MOLDED IN GALLONAGE MARKERS THIS TANK.

| | |
|---------------------|------------------------|
| CALCULATED CAPACITY | VOLUME IN U.S. GALLONS |
| DESIGN CAPACITY | 730 |

CONFIDENTIAL PROPERTY OF
 POLY PROCESSING COMPANY
 NOT FOR REPRINT OR USE
 WITHOUT PERMISSION

| | | | |
|--|------------|---|---|
| DWG TITLE | | 730 GALLON RECTANGULAR CONTAINMENT TANK | |
| SCALE: | 1/2"=1'-0" | | Western Region P.O. Box 80 8833 South Ash Street French Camp, CA 95824 (925) 985-4904 FAX (925) 985-5455 |
| DATE: | 6/22/00 | | DR: MB WILKERSON CK: J. BRANTLEY |
| REV "A" ADDED DIMENSION BY:MBW 3/10/03 CK:JB | | SHEET | COMPUTER FILE |
| | | 1 OF 1 | 15100730 A |