

NON-CONTROLLED COPY  
 INFORMATION SUBJECT TO CHANGE WITHOUT NOTICE  
 VERIFY REV LEVEL OF PAPER COPY WITH REV LEVEL ON PPC WEB SITE

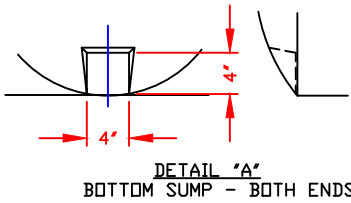
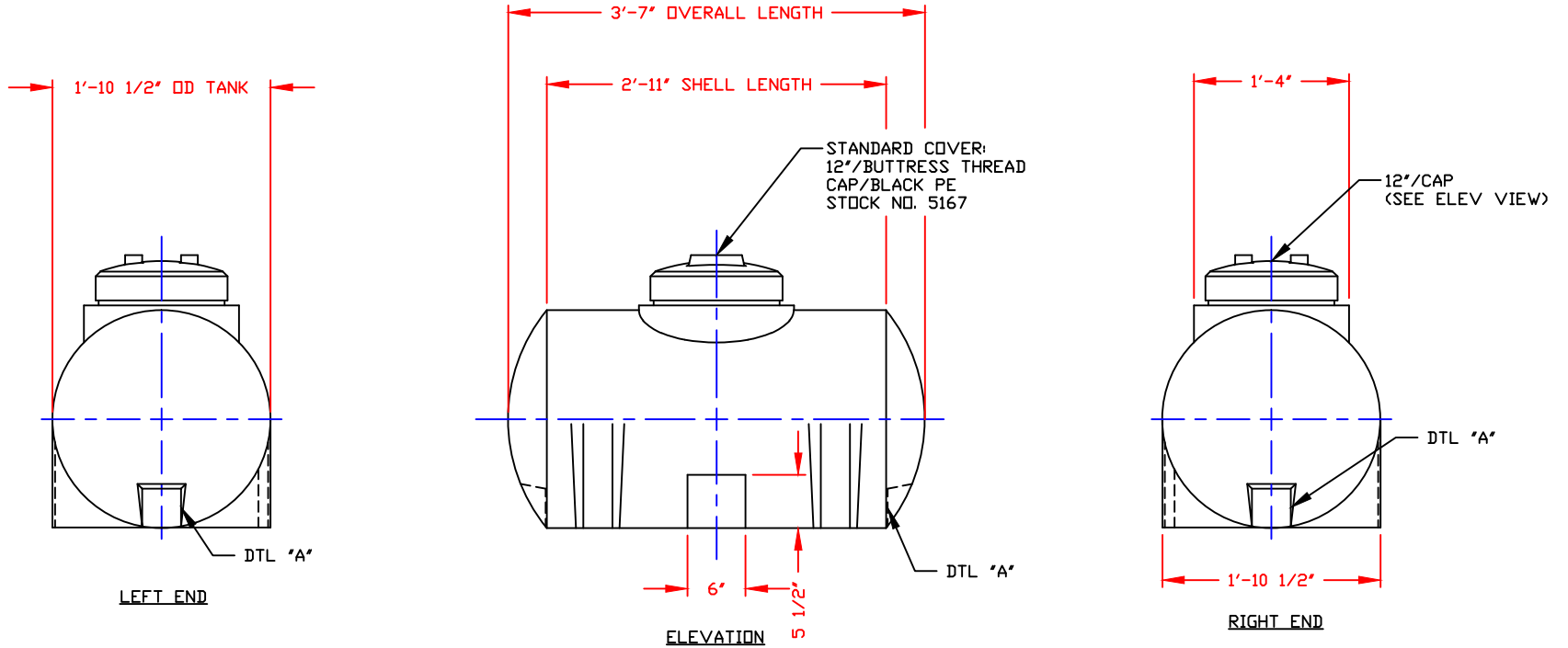

- NOTES**
1. THIS IS A COMPUTER GENERATED DWG. DO NOT REVISE BY HAND.
  2. DIMENSIONS WILL VARY ±3% DUE TO VARIATIONS IN MULTIPLE MOLDS & CONDITIONS PREVALENT DURING MANUFACTURE.
  3. MOLDED IN GALLONAGE MARKERS ON BOTH ENDS STARTING @ 10 GAL UP TO 60 GAL IN 10 GAL INCREMENTS. AVOID WHEN PLACING FITTINGS.

CALCULATED CAPACITY	VOLUME IN U.S. GALLONS
DESIGN CAPACITY	68

CONFIDENTIAL PROPERTY OF  
 PDLY PROCESSING COMPANY  
 NOT FOR REPRINT OR USE  
 WITHOUT PERMISSION

DWG TITLE			
66 GALLON HORIZONTAL LEG TANK			
SCALE:	1"=1'-0"	 Western Region P.O. Box 88 8855 South Ash Street French Camp, CA 95321 (209) 982-0994 FAX (209) 982-0425	DR: MB WILKERSON
DATE:	4/10/00		CK: D. RECTOR
		SHEET	COMPUTER FILE
		1 OF 1	13400066 -