

NON-CONTROLLED COPY INFORMATION SUBJECT TO CHANGE WITHOUT NOTICE COPY WILL <u>NOT</u> BE UPDATED	COPY ISSUED BY.....
	COPY ISSUED ON.....

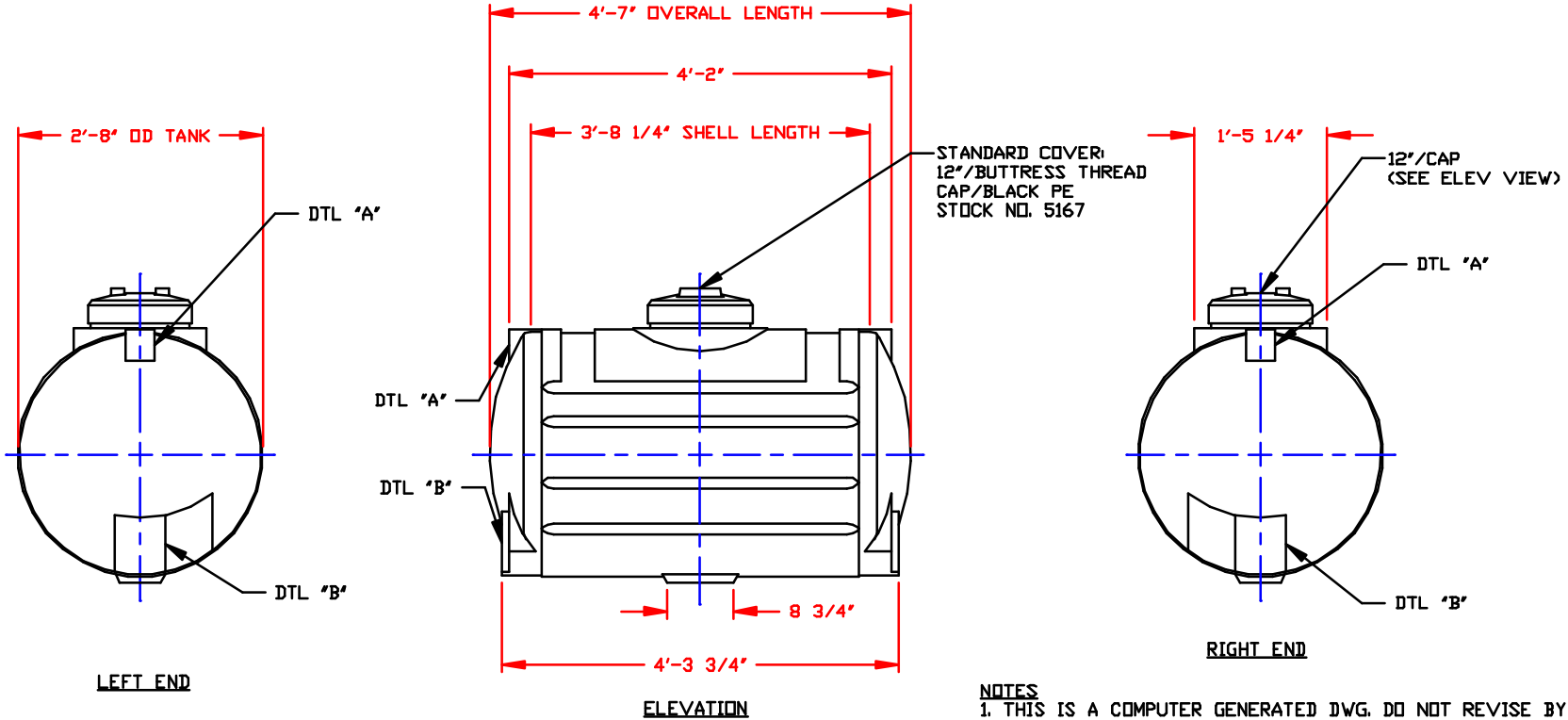

- NOTES**
1. THIS IS A COMPUTER GENERATED DWG. DO NOT REVISE BY HAND.
 2. DIMENSIONS MAY VARY ±3% DUE TO VARIATIONS IN MULTIPLE MOLDS & CONDITIONS PREVALENT DURING MANUFACTURE & USAGE.
 3. MOLDED IN GALLONAGE MARKERS IN BOTH ENDS STARTING @ 30 GAL UP TO 150 GAL. AVOID WHEN PLACING FITTINGS.

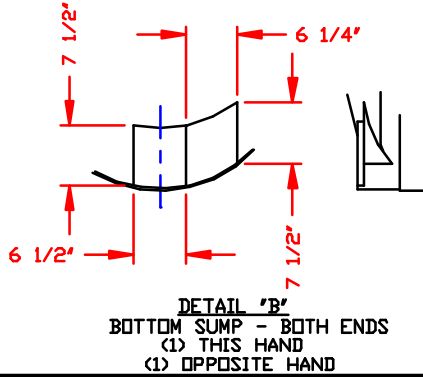
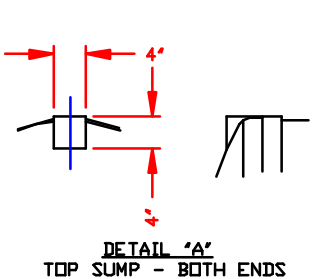

CALCULATED CAPACITY VOLUME IN U.S. GALLONS
DESIGN CAPACITY
174

CONFIDENTIAL PROPERTY OF
POLY PROCESSING COMPANY
NOT FOR REPRINT OR USE
WITHOUT PERMISSION

DWG TITLE		170 GALLON HORIZONTAL TANK	
SCALE	3/4"=1'-0"		DR: MB WILKERSON
DATE	4/4/00		CK: J. RECTOR
SHEET		COMPUTER FILE	REV
1 OF 1		13000170	-