

NON-CONTROLLED COPY  
 INFORMATION SUBJECT TO CHANGE WITHOUT NOTICE  
 VERIFY REV LEVEL OF PAPER COPY WITH REV LEVEL ON PPC WEB SITE

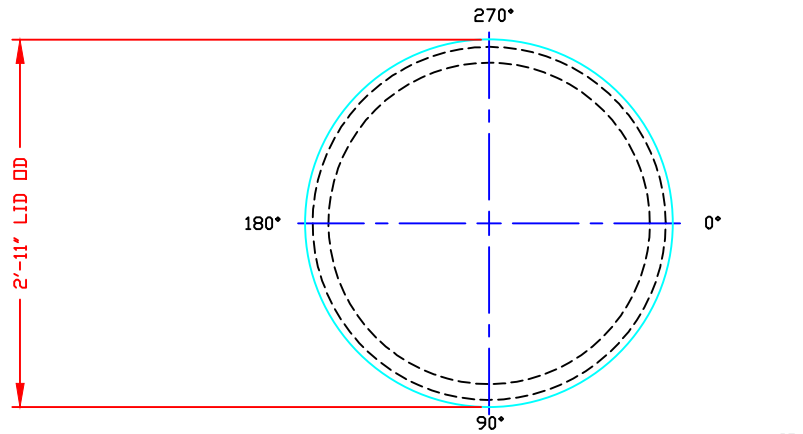

NOZZLE SCHEDULE & ACCESSORIES						
SERVICE	MK	STOCK NO.	SIZE	FITTING	DEG	ELEV

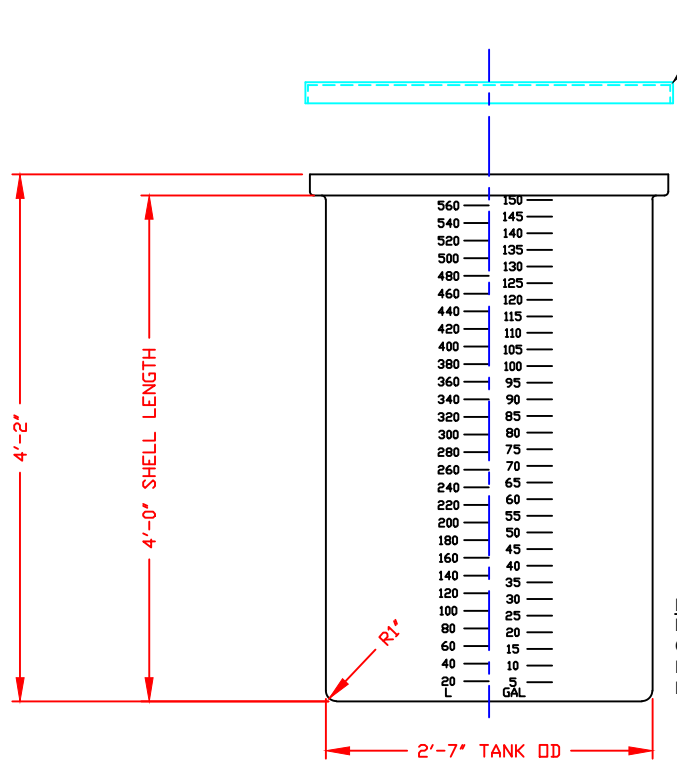

**NOTE:** MUST USE FLEXIBLE CONNECTIONS ALL LOWER SIDEWALL FITTINGS

- NOTES**
1. THIS IS A COMPUTER GENERATED DWG. DO NOT REVISE BY HAND.
  2. DIMENSIONS WILL VARY ±3% DUE TO VARIATIONS IN MULTIPLE MOLDS & CONDITIONS PREVALENT DURING MANUFACTURE & USAGE.
  3. MOLDED IN GALLONAGE MARKERS. AVOID WHEN PLACING FITTINGS.

CALCULATED CAPACITY	151
VOLUME IN U.S. GALLONS	
DESIGN CAPACITY	

CONFIDENTIAL PROPERTY OF  
 POLY PROCESSING COMPANY  
 NOT FOR REPRINT OR USE  
 WITHOUT PERMISSION

DWG TITLE			
150 GALLON OPEN TOP TANK W/LID			
SCALE:	1"=1'-0"	Western Region P.O. Box 88 8905 South Ash Street French Camp, CA 98521 (209) 962-4944 FAX (209) 962-0425	DR:
DATE:	5/4/01		CK:
		SHEET	COMPUTER FILE
		1 OF 1	11800150
			REV
			A