

NON-CONTROLLED COPY
 INFORMATION SUBJECT TO CHANGE WITHOUT NOTICE
 VERIFY REV LEVEL OF PAPER COPY WITH REV LEVEL ON PPC WEB SITE

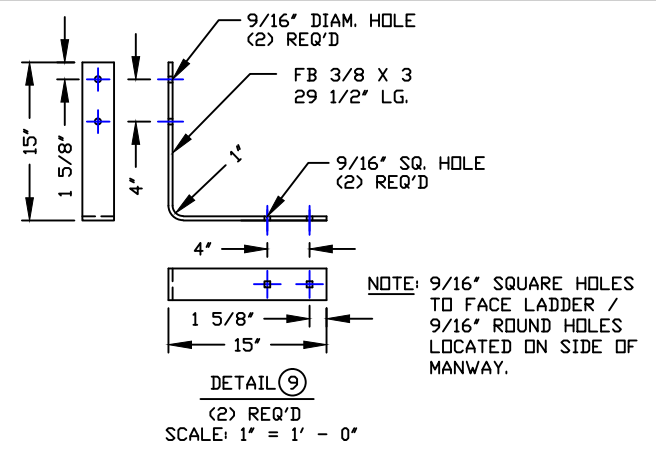

BOLTS INCLUDED WITH ASSEMBLY		
QTY.	BOLT SIZE	MARK
(4)	1/2" X 1 1/2"	A
(4)	1/2" CARRIAGE	B
(4)	1/2" PE ENCAPS.	C

NOTE: 3/4" ANCHORS TO BE SUPPLIED BY OTHERS.

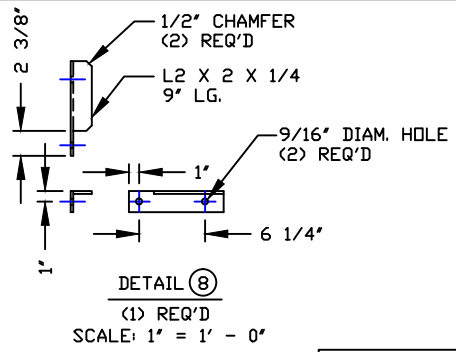
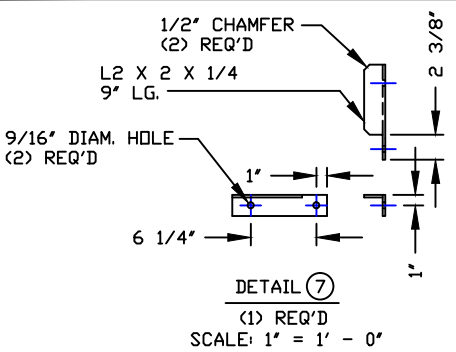
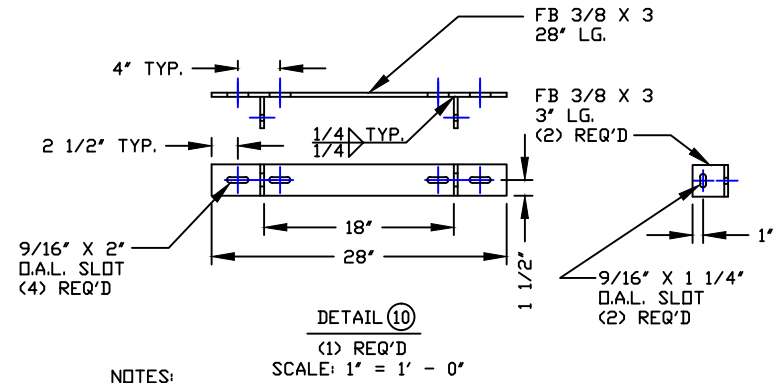
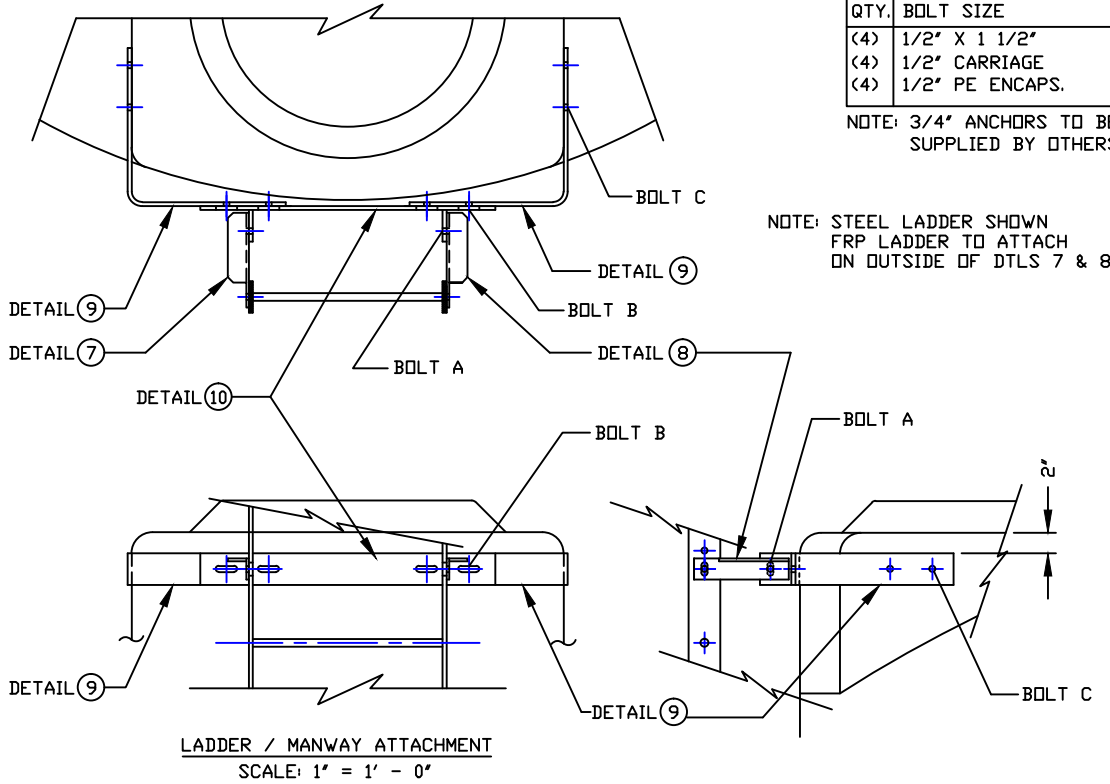

- NOTES:
1. THIS IS A COMPUTER GENERATED DRAWING. DO NOT REVISE BY HAND.
 2. COMPUTER DWG. NAME: 'LADAM' = SH. 1, 'LADBM' = SH. 2, 'LADCM' = SH. 3.
 3. FOR DIMENSIONS 'A,' 'B,' & 'C,' SEE LADDER DIMENSION SCHEDULE.

DWG TITLE		STEEL LADDER ASSEMBLY	
SCALE: 1/2"=1'-0"		Central Region P.O. Box 4590 (75150) 2550 Old Springington Rd. Bossier, LA 70605 CSD: 343-7863 FAX: CSD: 343-9795	DR: S. NEWBURY
DATE: 7/2/10		CHECKED: J. BRANTLEY	
		SHEET 1 OF 1	COMPUTER FILE LADCM
			REV -