

NON-CONTROLLED COPY  
 INFORMATION SUBJECT TO CHANGE WITHOUT NOTICE  
 VERIFY REV LEVEL OF PAPER COPY WITH REV LEVEL ON PPC WEB SITE

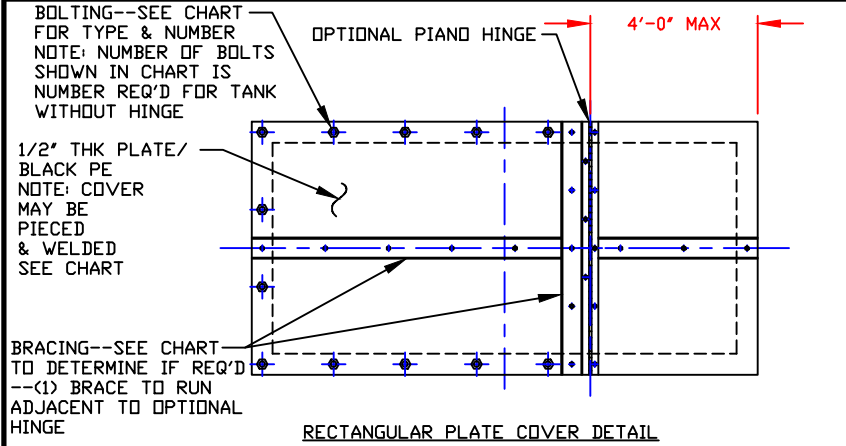
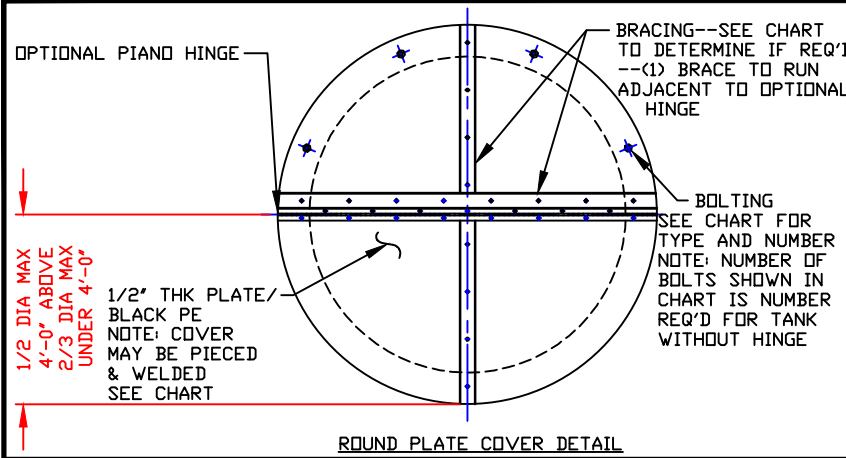

TANK STOCK NO.	TANK	COVER DIM	BOLT PATTERN	NO. BOLTS	*TYPE BOLTS	WLD	BRACE **
71500055	55 GAL OPEN TOP ***	30" DIA	27 1/2" BC	8	SS	NO	NO
74300055	55 GAL OPEN TOP 20° CONE	21" DIA	21" BC	4	PE	NO	NO
45100080	80 GAL RECT OPEN TOP	35" X 29"	33" X 27"	8	SS	NO	NO
41500110	110 GAL OPEN TOP ***	30" DIA	27 1/2" BC	8	SS	NO	NO
74300100	100 GAL OPEN TOP 20° CONE	32" DIA	29" BC	4	PE	NO	NO
41500160	160 GAL OPEN TOP ***	36" DIA	33 3/4" BC	8	SS	NO	NO
45100165	165 GAL RECT OPEN TOP	39" X 39"	38" X 38"	8	SS	NO	(1) PL
71500155	155 GAL OPEN TOP	37" DIA	34" BC	8	PE	NO	NO
41500220	220 GAL OPEN TOP ***	36" DIA	33 3/4" BC	8	SS	NO	NO
74300250	250 GAL OPEN TOP 20° CONE	42" DIA	39" BC	8	PE	NO	(1) PL
45100265	265 GAL RECT	53" X 50 1/2"	50 1/2" X 48"	12	SS	YES	(1) PL
41500330	330 GAL OPEN TOP ***	51" DIA	47 1/2" BC	8	SS	YES	(1) PL
71500360	360 GAL OPEN TOP	48" DIA	45" BC	8	PE	NO	(1) PL
45100385	385 GAL RECT OPEN TOP	70" X 47"	68" X 45"	14	SS	NO	(1) PL
41500470	470 GAL OPEN TOP ***	51" DIA	48 1/2" BC	8	SS	YES	(1) PL
71500505	505 GAL OPEN TOP	48" DIA	45" BC	8	PE	NO	(1) PL
71500575	575 GAL OPEN TOP	48" DIA	44" BC	8	PE	NO	(1) PL
71500570	570 GAL OVERFLOW BASIN	82" DIA	80" BC	16	SS	YES	(2) PL
45100635	635 GAL OPEN TOP RECT	45" X 117"	42" X 115"	16	SS	YES	(2) PL
45100645	645 GAL RECT	48" X 48"	46" X 46"	8	SS	NO	(1) PL
71500700	700 GAL OPEN TOP	61" DIA	58" BC	12	PE	YES	(1) PL
71500935	935 GAL CYL OVERFLOW BASIN	83" DIA	81 1/2" BC	16	SS	YES	(2) PL
71500960	960 GAL OPEN TOP	64" DIA	60" BC	8	PE	YES	(1) PL
71501100	1100 GAL OPEN TOP	61" DIA	58" BC	12	PE	YES	(1) PL
45101150	1150 GAL RECT	59 1/2" X 68 1/2"	59 1/2" X 68 1/2"	14	SS	YES	(1) PL
45101500	1500 GAL RECT	79" X 67"	79" X 67"	14	SS	YES	(1) PL
41502000	2000 OPEN TOP	92" DIA	89" BC	16	PE	YES	(2) PL

Bolt Type: \_\_\_\_\_

Gasket Material: \_\_\_\_\_

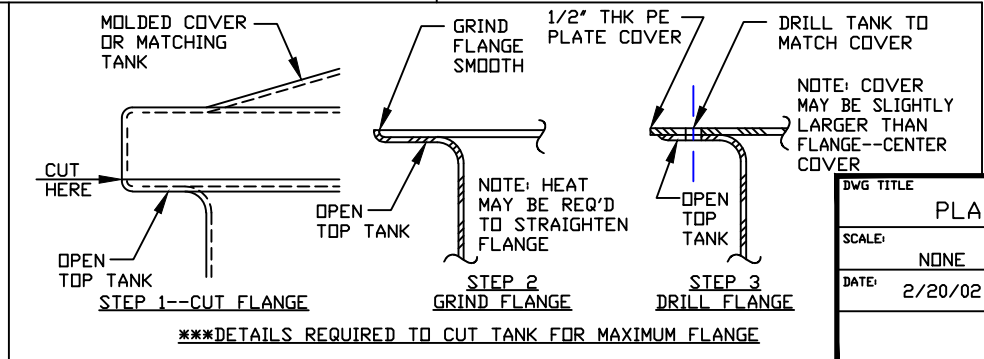
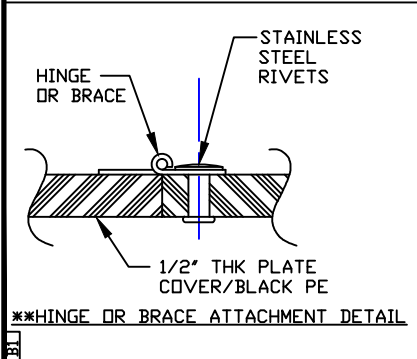

**NOTES**  
 1. THIS IS A COMPUTER GENERATED DWG. DO NOT REVISE BY HAND.  
 2. CHART FOR REFERENCE ONLY.

DWG TITLE: **PLATE COVERS FOR OPEN TOP TANKS**

SCALE: NONE

DATE: 2/20/02

Central Region  
 P.O. Box 4390 47820  
 2025 Old Sherrington Rd.  
 Horns, LA 70701  
 (504) 343-7660  
 FAX: (504) 343-8795

DR: M WILKERSON  
 CK: J. BRANTLEY

SHEET 1 OF 1

COMPUTER FILE: OTPLATEM

REV: -

POLYPROCESSING COMPANY LLC