

NON-CONTROLLED COPY  
 INFORMATION SUBJECT TO CHANGE WITHOUT NOTICE  
 VERIFY REV LEVEL OF PAPER COPY WITH REV LEVEL ON PPC WEB SITE

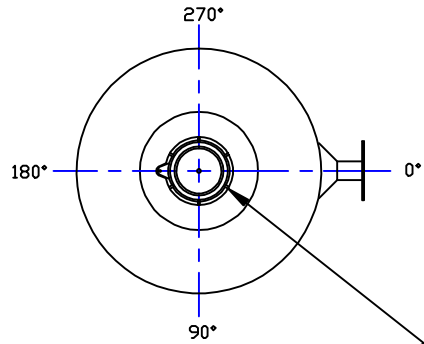

STANDARD COVER:  
 7" TH'D CAP/BLANK/CHMPLS/BLACK/PE  
 STOCK NO. 4565

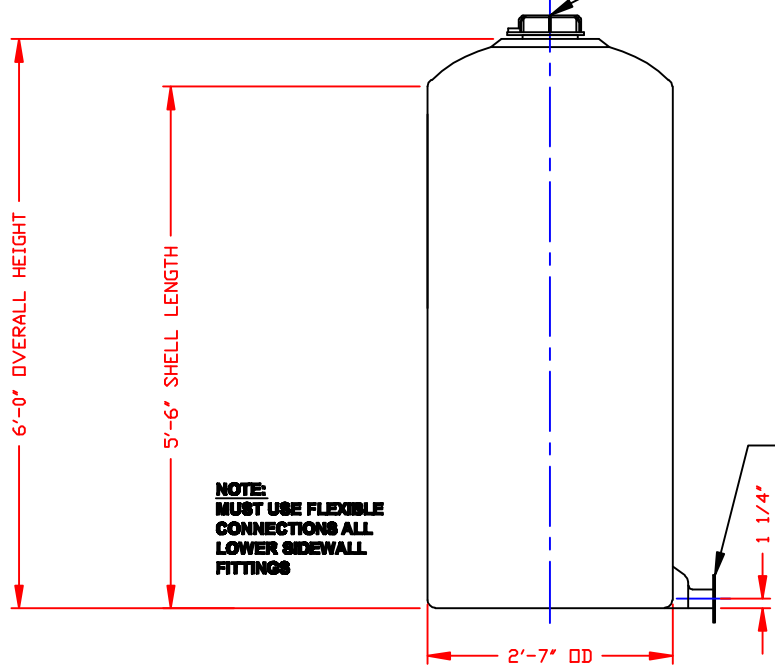

**NOTE:  
 MUST USE FLEXIBLE  
 CONNECTIONS ALL  
 LOWER SIDEWALL  
 FITTINGS**

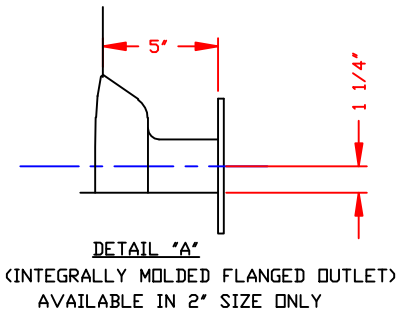

**NOTES**

1. THIS IS A COMPUTER GENERATED DWG. DO NOT REVISE BY HAND.
2. MOLDED IN GALLONAGE MARKERS IN 50 GALLON INCREMENTS UP TO 245 GALLON ON SIDEWALL.
3. DIMENSIONS WILL VARY ±3% DUE TO VARIATIONS IN MULTIPLE MOLDS & CONDITIONS PREVALENT DURING MANUFACTURE & USAGE.

CALCULATED CAPACITIES/ VOLUME IN U.S. GALLONS		
DESIGN CAP	DOME VOL	TOTAL VOL
210	9	219

CONFIDENTIAL PROPERTY OF  
 PDLY PROCESSING COMPANY  
 NOT FOR REPRINT OR USE  
 WITHOUT PERMISSION

DWG TITLE		200 GALLON IMFD TANK		
SCALE:	3/4"=1'-0"		DR:	J. BRANTLEY
DATE:	6/14/10		CK:	W. MANUEL
		SHEET	COMPUTER FILE	REV
		1 OF 1	11100200	-