

NON-CONTROLLED COPY
 INFORMATION SUBJECT TO CHANGE WITHOUT NOTICE
 VERIFY REV LEVEL OF PAPER COPY WITH REV LEVEL ON PPC WEB SITE

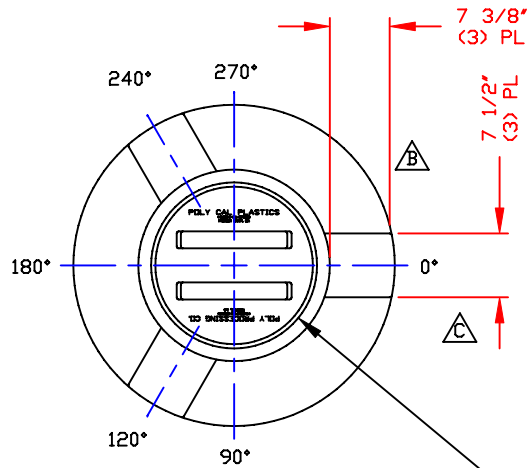

STANDARD COVER:
 17\"/>

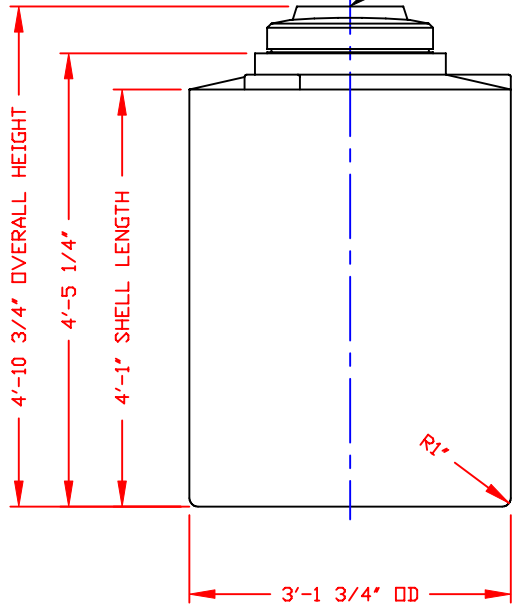

NOTE: A
 MUST USE FLEXIBLE
 CONNECTIONS ALL
 LOWER SIDEWALL
 FITTINGS

NOZZLE SCHEDULE & ACCESSORIES					
SERVICE	MK	STOCK NO.	SIZE	FITTING	DEG ELEV

- NOTES**
1. THIS IS A COMPUTER GENERATED DWG. DO NOT REVISE BY HAND.
 2. DIMENSIONS WILL VARY $\pm 3\%$ DUE TO VARIATIONS IN MULTIPLE MOLDS & CONDITIONS PREVALENT DURING MANUFACTURE & USAGE.
 3. MOLDED IN GALLONAGE MARKERS @ 0° IN 25 GAL INCREMENTS FROM 25 GAL UP TO 200 GAL. AVOID WHEN FITTING.

CALCULATED CAPACITIES/ VOLUME IN U.S. GALLONS	
DESIGN CAP	TOTAL VOL
236	249

CONFIDENTIAL PROPERTY OF
 POLY PROCESSING COMPANY
 NOT FOR REPRINT OR USE
 WITHOUT PERMISSION

DWG TITLE					
230 GALLON UPRIGHT TANK					
SCALE:	3/4"=1'	 POLYPROCESSING COMPANY	<small>Western Region</small> <small>P.O. Box 80</small> <small>8035 South 4th Street</small> <small>French Camp, CA 95021</small> <small>(925) 962-4364</small> <small>FAX (925) 962-0425</small>		DR:
DATE:	2/28/00		CK:	D. RECTOR	
REV 'C' FLATS ADDED TO TOP BY:MBW 6/27/05 CK:JB		SHEET		COMPUTER FILE	REV
REV 'B' REMOVED FITTING FLAT @ 340° BY:MBW 6/27/05 CK:JB		1 OF 1		11000230	C
REV 'A' ADDED FITTING NOTE BY:JB 2/27/03 CK:MBW					