

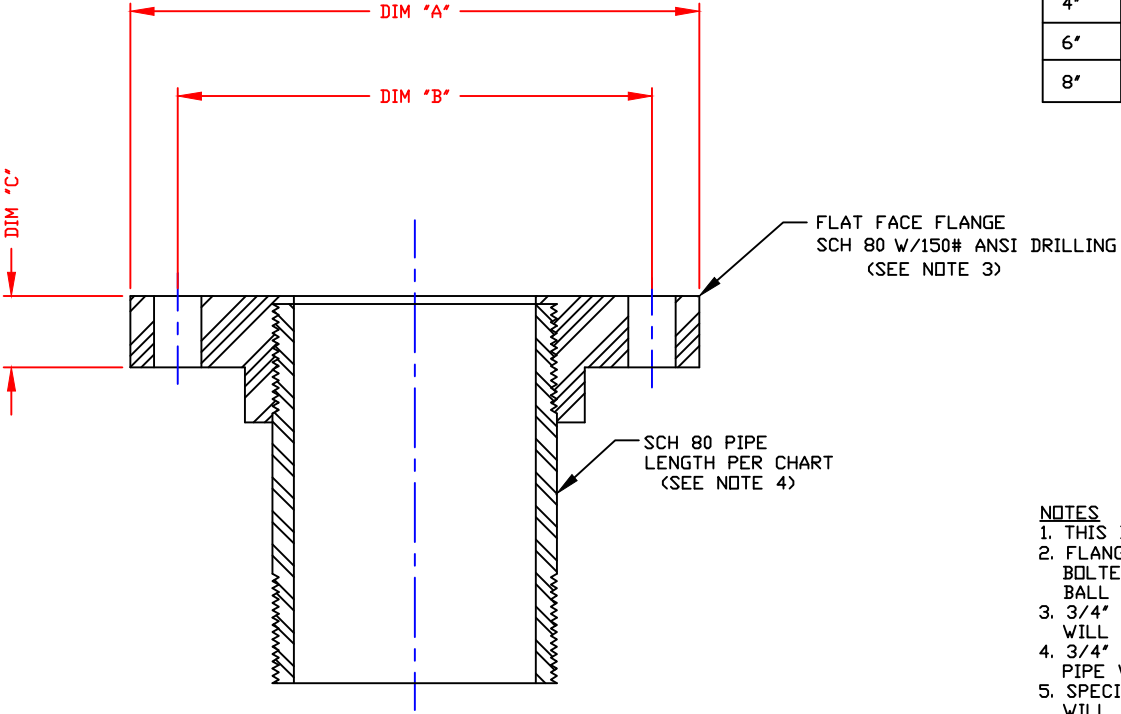

NON-CONTROLLED COPY  
 INFORMATION SUBJECT TO CHANGE WITHOUT NOTICE  
 VERIFY REV LEVEL OF PAPER COPY WITH REV LEVEL ON PPC WEB SITE

Fitting Size:
Fitting Material:
Flange Type:
Gasket Material:

PIPE SIZE	DIM "A"	DIM "B"	DIM "C"	DIA BOLT HOLES	NO. BOLT HOLES	PIPE LENGTH
1/2"	3 1/2"	2 3/8"	9/16"	1/2"	4	4
3/4"	3 7/8"	2 3/4"	1/2"	1/2"	4	4
1"	4 1/4"	3 1/8"	5/8"	1/2"	4	4
1 1/2"	5"	3 7/8"	11/16"	1/2"	4	4
2"	6"	4 3/4"	3/4"	5/8"	4	4
3"	7 1/2"	6"	15/16"	5/8"	4	4"
4"	9"	7 1/2"	1 1/8"	5/8"	8	6"
6"	11"	9 1/2"	1 1/4"	3/4"	8	8
8"	13 1/2"	11 3/4"	1 7/16"	3/4"	8	12"



- NOTES**
1. THIS IS A COMPUTER GENERATED DWG. DO NOT REVISE BY HAND.
  2. FLANGE ADAPTERS MAY BE THREADED INTO BULKHEAD FTGS, BOLTED FLANGE FTGS, FEMALE SS BULKHEAD FTGS OR UNIVERSAL BALL DOME FTGS.
  3. 3/4" THRU 4" FLANGES WILL BE THREADED/6" & 8" FLANGES WILL BE SOCKET FLANGES, UNLESS SPECIFIED OTHERWISE.
  4. 3/4" THRU 4" PIPE WILL BE THREADED BOTH ENDS/6" & 8" PIPE WILL BE STRAIGHT PIPE, UNLESS SPECIFIED OTHERWISE.
  5. SPECIAL SS FLANGE ADAPTERS CAN BE ORDERED. ALL SIZES WILL BE THREADED.

DWG TITLE			
FLANGE ADAPTER			
SCALE:	6"=1'-0"	 Central Region P.O. Box 4590 FRENCH 2284 Old Worthington Rd. Norcross, GA 30092 (770) 343-7843 FAX (770) 343-9795	DR: C. DAVIES
DATE:	4/28/10		CK: J. BRANTLEY
		SHEET	REV
		1 OF 1	FLGADPTM -