

NON-CONTROLLED COPY
 INFORMATION SUBJECT TO CHANGE WITHOUT NOTICE
 VERIFY REV LEVEL OF PAPER COPY WITH REV LEVEL ON PPC WEB SITE

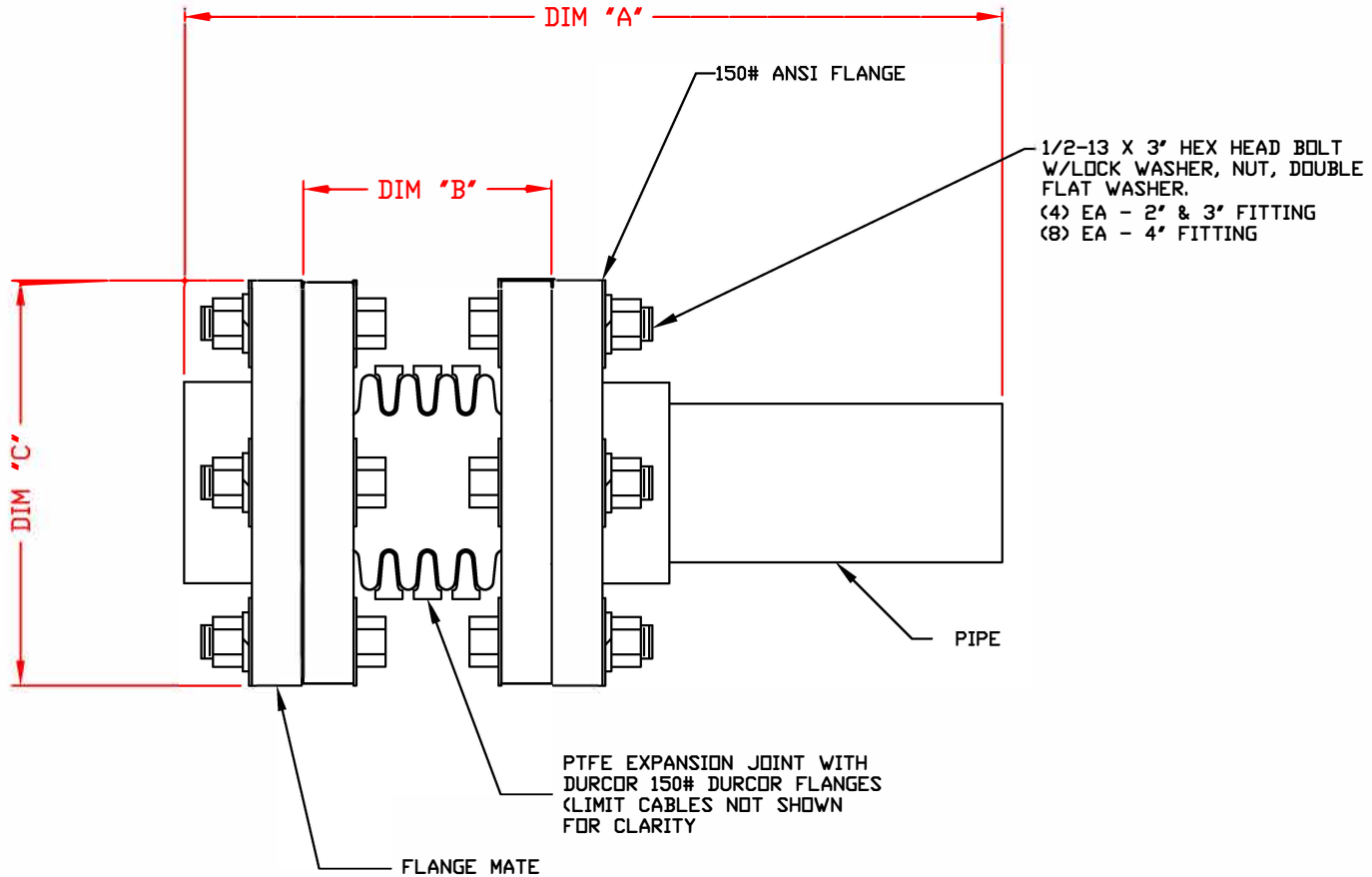

Fitting Size:
Flange Type:
Flange Material:
Bolt Type:
Gasket Material:
Optional Flange:
Optional Liner Sleeve:

PIPE SIZE (NPT)	DIM A	DIM B	DIM C
1"	9 1/4'	3 3/8'	4 1/4'
2"	12 3/4'	3 11/16'	6'
3"	14 1/4'	4 5/8'	7 1/2'
4"	15'	4 3/4'	9'
6"	16 1/4'	5'	11'

NOTES
 1. THIS IS A COMPUTER GENERATED DWG. DO NOT REVISE BY HAND.

DWG TITLE FLEXIJJOINT/FLANGEMATE ASSEMBLY			
SCALE: 6"=1'-0"	 Central Region P.O. Box 4020 GREENWOOD 8001 Elm Street, Houston, TX Houston, TX 77056 (281) 343-7765 FAX (281) 343-6795	DR: J. BRANTLEY	REV
DATE: 12/26/18		CK: C. DAVIES	
SHEET 1 OF 1		COMPUTER FILE FLXJNTFLGMATEM	REV A

REV 'A' - REVISED SCHEDULE FOR DIMENSION 'B'-12/26/2018 B.T